



*turbob*

TERO

SPECIALIZED  
UNIVERSITY

FEATURES, BENEFITS  
& GUIDELINES WORKBOOK





## DEAR SPECIALIZED RETAILER AND SPECIALIZED EMPLOYEE,

Some of us like to explore out of bounds. Not everyone is content with living their lives in one lane. As riders, it is too easy for us to be categorized in confining terms: everyday commuter, roadie, mountain biker, trekker, weekend warrior... What if there was a bike that could offer more than a single experience, a bike that could effectively straddle these different worlds and offer us the ability to ride where we want, how we want, when we want? A bike that could let us immerse ourselves in the mountain bike experience, AND a bike that you could wipe the mud off after a weekend on the trails and count on it to get you everywhere you need to go with confidence and ease.

Meet the new Specialized Tero: A mountain bike that you can commute on. A commuter you can take touring. A touring bike that you can haul freight with. Whatever you need it to be, for wherever you want to go. A true do-it-all superhero, Tero combines adaptable utility with World Champion mountain bike DNA and class leading electric assist. Tero empowers you to explore new horizons, turn every ride into an adventure, to ride wherever that adventure leads. You'll have to supply your own cape, but Tero will handle the rest.

## ABOUT THIS WORKBOOK

Specialized University have developed this product-focused Workbook to help you become a Turbo Tero expert. It is a profound source of product knowledge that guides you through all features and benefits. Combined with your own ride experience, it empowers you to answer any Rider questions so that they get the most from their bikes and rides. But this is not everything - we have created more resources for you to successfully work with the new Turbo Active bikes. To name three of them:

- Workbook 'Full Power System: Features & Benefits' - covers the used Turbo Technology in detail
- [SBCU.com](https://www.sbcu.com) product videos - cover key product knowledge
- Resources on the Service Website - cover specific aspects around service & repair (build and setup videos/animations, schematics, spare parts etc.)

Please refer to your market contacts for more assets in your language and go to the Service Website to access the technical documentation.

## OUR ASKS FOR USING THIS WORKBOOK

- Keep it and its value within your business - this document is meant to be a source of knowledge exclusively for Turbo Retailers and Specialized staff
- Read it at least once in its entirety so that you know the content
- Use the clickable table of contents to find your desired topic
- Use the zoom function to enlarge small text or tables
- Use the search function (Ctrl+f) to scan the document for key words
- Use it to host product presentations to your teams and colleagues

*We wish you lots of success with the all-new Active category and many inspiring moments out riding!*

*- The Specialized Turbo Team*

Disclaimer: The content of this Workbook was compiled according to best knowledge and with greatest care. Yet, all data is subject to change. Regular corrections and additions will make sure the content stays up-to-date.



## EXPERIENCE

|                            |   |
|----------------------------|---|
| THE POWER TO RIDE ANYWHERE | 4 |
| QUICK PROFILE              | 5 |

## MODEL OVERVIEW

|                    |    |
|--------------------|----|
| COMMONALITIES      | 6  |
| COMMONALITIES      | 6  |
| KEY SPECIFICATIONS | 7  |
| BIKE WEIGHTS       | 9  |
| SIZE GUIDE         | 9  |
| BIKE GEOMETRY      | 10 |

## THE CHASSIS

|   |    |
|---|----|
| FRAME DESIGN AND ENGINEERING ACHIEVEMENTS | 11 |
| FRAME MEASUREMENTS & COMPATIBILITY        | 12 |
| FORK MEASUREMENTS & COMPATIBILITY         | 13 |

## KEY COMPONENT DATA

|                                |    |
|--------------------------------|----|
| OVERVIEW: EQ VS. VON-EQ MODELS | 14 |
| TERO EQ: RACK, FENDERS, LIGHTS | 15 |
| LIGHT DETAILS                  | 16 |
| CONVERTING NON-EQ TO EQ MODEL  | 17 |
| COCKPIT                        | 17 |
| SEATING AREA                   | 18 |
| DRIVE-TRAIN SPECIFICATIONS     | 18 |
| WHEELS & TIRES                 | 19 |
| KICKSTAND                      | 20 |

## ACCESSORY COMPATIBILITY

|                            |    |
|----------------------------|----|
| CARRYING SOLUTIONS & LOCKS | 21 |
| TRAILER USE                | 23 |
| CHILDSEAT USE              | 23 |

## TURBO FULL POWER TECHNOLOGY

|                                |    |
|--------------------------------|----|
| GENERAL                        | 24 |
| BASIC THEORY OF OPERATION      | 24 |
| MOTOR                          | 25 |
| BATTERY                        | 27 |
| CHARGERS & CHARGING            | 28 |
| BATTERY REMOVAL & INSTALLATION | 29 |
| BATTERY LOCK MECHANISM         | 31 |
| MASTERMIND TCD                 | 32 |
| FIRMWARE UPDATES (WIRED)       | 33 |
| FIRMWARE UPDATES (WIRELESS)    | 33 |

## WIRELESS CONNECTIVITY

|                          |    |
|--------------------------|----|
| GENERAL                  | 34 |
| MISSION CONTROL APP      | 34 |
| TURBO SYSTEM LOCK        | 35 |
| THIRD PARTY ANT+ OPTIONS | 36 |
| GARMIN WIRELESS RADAR    | 36 |

## RANGE & RIDE TIME

|                                    |    |
|------------------------------------|----|
| RANGE CONVERSION & RANGE VARIABLES | 37 |
| TIPS TO OPTIMIZE RANGE             | 37 |
| SIMPLIFIED RANGE TABLES            | 38 |

## BIKE BUILDING & SERVICE

|                               |    |
|-------------------------------|----|
| OVERVIEW                      | 39 |
| DIAGNOSTICS & TROUBLESHOOTING | 40 |

## SERVICE & REPAIR (RETAILER)

|               |    |
|---------------|----|
| SERVICE PARTS | 41 |
| SPOKE LENGTHS | 41 |

## GUIDELINES & TIPS

|                              |    |
|------------------------------|----|
| RIDING TIPS                  | 42 |
| TRANSPORTATION TIPS          | 42 |
| CLEANING GUIDELINE           | 43 |
| STRUCTURAL WEIGHT LIMITS     | 44 |
| USER MANUAL & YELLOW STICKER | 44 |



## **EXPERIENCE** **THE POWER TO RIDE ANYWHERE**

There are places beyond these city streets, with paths and trails that beckon to your subconscious. Breathtaking views, air that refreshes your soul. They wait, seemingly too far away. Go there. Ride there. Now. The all new Tero is your ticket to new horizons, your escape vehicle from the mundane.

Combining rugged mountain bike handling and capability with a Full Power 2.2 motor, Tero gives your legs and heart an intuitive helping hand, allowing you to expand your riding horizons wherever and however you choose to ride. Tero empowers you to ride farther, more confidently, and to explore new landscapes.



# EXPERIENCE

## QUICK PROFILE



### TERO

|                                    |   |
|------------------------------------|---|
| STATEMENT                          | The Power to Ride Anywhere  |
| CHARACTER                          | Unrivaled Power, Confidence and Versatility   |
| WEIGHT                             | <ul style="list-style-type: none"> <li>• 22.7 - 23.8 kg</li> <li>• 50 - 52.5 lbs</li> </ul>   |
| MODERN MOUNTAIN BIKE GEOMETRY      | <ul style="list-style-type: none"> <li>• Stable and responsive</li> <li>• Comfortable, upright position</li> <li>• Balanced, confidence inspiring handling</li> </ul>   |
| SUPERNATURAL POWER                 | <p><b>Quiet, smooth and powerful motors:</b></p> <ul style="list-style-type: none"> <li>• 560 W / 90 Nm / 4x you (5.0 models)</li> <li>• 470 W / 70 Nm / 4x you (4.0 models)</li> <li>• 430 W / 50 Nm / 4x you (3.0 models)</li> </ul>  |
| RIDE ANYWHERE RANGE                | <p><b>Max. Range, default Eco mode*:</b></p> <ul style="list-style-type: none"> <li>• Up to 145 km / 90 mi</li> <li>• Up to 6:30 h ride time (25 kph speed limit, 710 wh battery)</li> </ul>  |
| RICH & CUSTOMIZABLE USER INTERFACE | <ul style="list-style-type: none"> <li>• Full color MasterMind TCD</li> <li>• Customizable display to show more than 30 metrics and 16 screens</li> <li>• Bluetooth / ANT+ connectivity</li> <li>• USB C side-port to charge external devices (1A)</li> </ul>   |
| ADDED SAFETY & SECURITY            | <ul style="list-style-type: none"> <li>• All models compatible with Garmin ANT+ aftermarket radar</li> <li>• System Lock through MC for all models</li> </ul>   |
| MORE VERSATILITY                   | <p><b>One bike for all seasons, all terrain, all purposes:</b></p> <ul style="list-style-type: none"> <li>• A mountain bike that you can commute on</li> <li>• A commuter you can take touring</li> <li>• A touring bike that you can haul freight with</li> </ul> <p><b>Not only multiple accessory options such as locks and carrying solutions, but also:</b></p> <ul style="list-style-type: none"> <li>• Optional front rack</li> <li>• Trailer-compatible</li> <li>• EQ model: Child seat compatible</li> </ul> |
| MORE FLEXIBILITY                   | <p><b>One EQ model and all models convertible to EQ version:</b></p> <ul style="list-style-type: none"> <li>• EQ models with rack, fenders, lights and kickstand</li> <li>• Tero EQ kit to upgrade non-EQ models</li> </ul>   |

\* Range varies by market speed limits, support settings and other variables; see range chapter for more data and details



# MODEL OVERVIEW COMMONALITIES

- Identical frames across the family, all in sizes S, M, L and XL
- All models feature suspension forks with 110mm travel
- All bikes roll on 29" wheels
- All models feature the Turbo Full-Power Technology - important: there are three different motor performance types and two battery capacities!
  - All batteries are lockable and removable with the key lock
  - All come with the MasterMind TCD and a wired handlebar remote



TURBO TERO 3.0 IN OAK GREEN METALLIC / SMOKE

# MODEL OVERVIEW DIFFERENTIATORS

## MOTOR PERFORMANCE AND BATTERY CAPACITY

- 5.0 models: Specialized 2.2 motor + 710 Wh battery
  - Max. motor performance: 560 watts / 90 Nm
- 4.0 models: Specialized 2.0 motor + 710 Wh battery
  - Max. motor performance: 470 watts / 70 Nm
- 3.0 models: Specialized 2.0E motor + 530 Wh battery
  - Max. motor performance: 430 watts / 50 Nm

## EQ MODEL VS. NON-EQ MODELS

- The Tero 4.0 EQ comes with rack, fenders, lights and a kickstand
- All other models are upgradeable, using the TERO EQ KIT

## STEP MODELS

- Tero 4.0 and 3.0 models are available both as step-through versions and as double diamond version
- Tero 5.0 is only available as double diamond version

## COMPONENTS

### Forks

- RockShox with Boost standard (110 mm spacing)
- Suntour models with standard spacing (100 mm)

### Drivetrain

- 5.0 and 4.0 models are 1x11 spd with 11-42t cassettes
- 3.0 models are 1x9 spd with 11-36t cassettes
- EQ models: 40t chainrings
- Non-EQ models: 36t chainrings

### Brakes

- 5.0 and 4.0 models: 4-piston SRAM brakes with 200/180 mm rotor spec
- 3.0 models: 2-piston Shimano brakes with 180/180 mm rotor spec

### Seatposts

- 5.0 and 4.0 models: TransX dropper post with 100/120 mm travel (S/M-XL)
- 3.0 models: rigid alloy seatpost



# MODEL OVERVIEW

## KEY SPECIFICATIONS

This table is subject to change w/o notice, for full spec table visit [www.specialized.com](http://www.specialized.com)

|                                     | <b>TERO 5.0</b><br>(Double Diamond)   | <b>TERO 4.0</b><br>(Double Diamond / Step)   | <b>TERO 4.0 EQ</b><br>(Double Diamond / Step) | <b>TERO 3.0</b><br>(Double Diamond / Step)  |
|-------------------------------------|---|--|---|---|
| <b>FRAME</b>                        | E5 Aluminum, bottom bracket motor mount, fully integrated & lockable downtube battery, internal cable routing, lock mount, front and rear rack mounts |  |   |   |
| <b>MOTOR</b>                        | Specialized 2.2<br>250 w nominal<br>90 Nm / 560 w max.  | Specialized 2.0<br>250 w nominal<br>70 Nm / 470 w max  |   | Specialized 2.0E<br>250 w nominal<br>50 Nm / 430 w max.   |
| <b>BATTERY</b>                      | Specialized SBC - B20<br>710 Wh   |  |   | Specialized SBC - B19<br>530 Wh   |
| <b>USER INTERFACE</b>               | Specialized MasterMind TCD, customizable color display, on/off button, wired to handlebar remote, Bluetooth®/ANT+ connectivity, USB C charging        |  |   |   |
| <b>FORK</b>                         | RockShox Recon Silver RL, 110mm travel, Motion-Control, fender mounts 15x110 mm (Boost) 42 mm offset  | RockShox Recon Silver TK, 110mm travel, Motion-Control, fender mounts 15x110 mm (Boost) 42 mm offset   |   | SR Suntour XCM32, 110mm travel, lockout, fender mounts 15x100 mm (standard) 46 mm offset  |
| <b>SHIFT SYSTEM</b>                 | <b>Shifter:</b><br>SRAM S700, single-click lever<br><b>Derailleur:</b><br>SRAM GX, long cage, 11-speed  | <b>Shifter:</b><br>SRAM NX, 11spd<br><b>Derailleur:</b><br>SRAM NX, long cage, 11-speed  |   | <b>Shifter:</b><br>Shimano Alivio SL-M3100-R, 9spd, Rapid-fire Plus, w/optical gear display<br><b>Derailleur:</b><br>Shimano Alivio RD-M3100, 9spd, Shadow Design |
| <b>CHAINRING / CASSETTE / CHAIN</b> | <b>Chainring:</b><br>36t, custom<br><b>Cassette:</b><br>SRAM PG-1130, 11-speed, 11-42t<br><b>Chain:</b><br>KMC e11T, 11-speed w/ Missing Link™        | <b>Chainring:</b><br>36t, custom<br><b>Cassette:</b><br>SRAM PG-1130, 11-speed, 11-42t<br><b>Chain:</b><br>KMC e11s, 11-speed w/ Missing Link™ | as TERO 4.0, yet 40t chainring                | <b>Chainring:</b><br>36t, custom<br><b>Cassette:</b><br>Shimano CS-HG400, 9-speed, 11-36t<br><b>Chain:</b><br>KMC e9T, 9-speed w/ Missing Link™                   |
| <b>BRAKES</b>                       | SRAM G2 RS, 4-piston calipers, hydraulic disc, 200/180 mm discs front/rear  | SRAM Guide T, 4-piston calipers, hydraulic disc, 200/180mm discs front/rear  |   | Shimano BR-MT200, 2-piston calipers, hydraulic disc, 180mm discs front and rear   |



# MODEL OVERVIEW

## KEY SPECIFICATIONS

|  | <b>TERO 5.0</b><br>(Double Diamond)  | <b>TERO 4.0</b><br>(Double Diamond / Step)   | <b>TERO 4.0 EQ</b><br>(Double Diamond / Step)  | <b>TERO 3.0</b><br>(Double Diamond / Step) |
|--|--|--|--|--|
| <b>WHEELS</b><br>(ALL 29, 32H,<br>DT SWISS IND.<br>SPOKES) | <b>Rear hub:</b><br>Alloy, sealed cartridge bearings, 12x148mm thru-axle, 32h<br><b>Front hub:</b><br>Alloy, sealed cartridge bearings, 15x110mm thru-axle, 32h<br><b>Rims:</b><br>Stout XC 29, 25mm internal width, disc-specific |  | <b>Rear hub:</b><br>Shimano MT400, Center-lock 32h, 12x148 Boost<br><b>Front hub:</b><br>Shimano MT400, Center-lock 32h, 15x100mm<br><b>Rims:</b><br>650b disc, double-wall alloy, 20mm rim depth, 30mm internal width |  |
| <b>TIRES</b>   | Specialized Ground Control 29x2.35, tubeless ready (2BR)   |  |  |  |
| <b>SEATPOST</b>  | TranzX Dropper, 30.9mm, 0mm setback,<br>S: 100mm travel<br>M-XL: 120mm travel  |  | Specialized, 6061 alloy,<br>2-bolt clamp, 0mm setback, 30.9mm  |  |
| <b>LIGHTS</b>  | n.a.<br>(upgrading possible)   | <b>Front:</b><br>Lezyne Hecto St-VZO E65, 210 Lumen, fork-mounted<br><b>Rear:</b><br>Spanninga Commuter Glow, fully rack-integrated, 50 miniature LEDs, 2,5 Cd (full angle), replaceable |  | n.a.<br>(upgrading possible)               |
| <b>RACK / FENDER</b>                                       | n.a.<br>(upgrading possible)   | Specialized rack, MIK HD interface, built-in pannier mounts, 27kg max load<br>Specialized DRYTECH fenders, 65mm width, aluminum fenderstay   |  | n.a.<br>(upgrading possible)               |





# MODEL OVERVIEW

## BIKE WEIGHTS

- Deviations for same size/model can occur. e.g. due to paint scheme and tire tolerances
- Difference between double diamond and step frames is negligible

|  | APPROX. WEIGHTS<br>(SIZE M, WITH PEDALS) |
|--|--|
| TERO 5.0<br>(Double Diamond)           | 22.7 kg / 50 lbs                         |
| TERO 4.0<br>(Double Diamond / Step)    | coming soon                              |
| TERO 4.0 EQ<br>(Double Diamond / Step) | 25.5 kg / 56.2 lbs                       |
| TERO 3.0<br>(Double Diamond / Step)    | 23.2 kg / 51.2 lbs                       |



# MODEL OVERVIEW

## SIZE GUIDE

Note that this is a first indication only. Rider preferences and individual physiology can lead to deviations from these recommendations. Ideally, sizing is determined in a professional Retul/Body Geometry session and the rider gets a full fitting to create the perfect experience. A proper test ride should be part of the size decision as well.

|    | APPROX. WEIGHTS<br>(SIZE M, WITH PEDALS)    |
|----|---|
| S  | 155 - 165 cm<br>5 ft, 1 in - 5 ft, 5 in     |
| M  | 165 - 178 cm<br>5 ft, 5 in - 5 ft, 10.1 in  |
| L  | 175 - 185 cm<br>5 ft, 8.9 in - 6 ft, 0.8 in |
| XL | 185 - 195 cm<br>6 ft, 0.8 in - 6 ft, 4.8 in |





# MODEL OVERVIEW

## BIKE GEOMETRY

We've packaged our own lessons learned from forty years of making the best handling mountain bikes in the world into Tero's chassis, and the result is a responsive, stable, super-capable bike that improves your ride, everywhere from urban potholes to alpine singletrack.



| PARAMETER   | TERO<br>FRAME SIZE |       |       |       |
|---|--------------------|-------|-------|-------|
|   | S                  | M     | L     | XL    |
| Stack (mm)  | 637                | 651   | 664   | 687   |
| Reach (mm)  | 405                | 426   | 446   | 462   |
| Head Tube Length (mm)                               | 135                | 150   | 165   | 190   |
| Head Tube Angle (°)                                 | 66.4               | 66.4  | 66.4  | 66.4  |
| BB Height (mm)                                      | 313                | 313   | 313   | 313   |
| BB Drop (mm)  | 57                 | 57    | 57    | 57    |
| Trail (mm)  | 114                | 114   | 114   | 114   |
| Fork Length (full) (mm)                             | 516                | 516   | 516   | 516   |
| Fork Rake/Offset (mm)                               | 44                 | 44    | 44    | 44    |
| Front Center (mm)                                   | 709                | 736   | 761   | 787   |
| Chainstay Length (mm)                               | 470.4              | 470.4 | 470.4 | 470.4 |
| Wheelbase (mm)                                      | 1173               | 1200  | 1226  | 1252  |
| Toptube Length (horizontal) (mm)                    | 589                | 620   | 650   | 680   |
| Bike Standover Height (mm)<br>Double Diamond frames | 773                | 807   | 807   | 835   |
| Bike Standover Height (mm)<br>Step-through frames   | 658                | 655   | 655   | 664   |
| Seat Tube Length (mm)                               | 400                | 450   | 460   | 500   |
| Seat Tube Angle (Virtual) (°)                       | 73.9               | 73.4  | 72.9  | 72.4  |



# THE CHASSIS

## FRAME DESIGN AND ENGINEERING ACHIEVEMENTS

### GENERAL

- Create an all-new alloy frame that utilizes modern mountain bike geometry with emphasis on both stability and responsiveness
- Offer double diamond and step-through frames, so that Riders can choose based on their preference
- Tailor the cockpit dimensions for a comfortable, balanced fit that positions Riders for optimum control, resulting in balanced, confidence inspiring handling, regardless of the terrain challenges
- Integrate our latest Full Power Turbo e-bike Technology for a smooth, powerful ride, long range and easy battery handling
- Give Riders a versatile platform so that they can use multiple accessories or even upgrade their non-EQ model with the dedicated TERO EQ KIT (fenders, rack, lights)
- Include trailer-compatibility and allow upgrading with a front rack
- Peace of mind with integrated frame lock-mounts (seat stays)



### ALUMINUM PROPERTIES

- All Tero chassis are constructed from our light-yet-strong E5 Premium Aluminum
- Smooth Welds for elegant transitions



# THE CHASSIS

## FRAME MEASUREMENTS & COMPATIBILITY

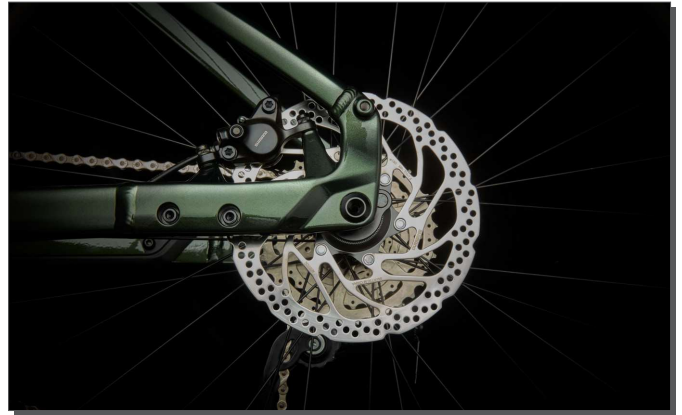

### MOTOR INTEGRATION

- Fully integrated horizontally and secured by 3 bolts
- Clean & stable integration
- New 2-piece motor covers (black only)

### BATTERY INTEGRATION

- Battery is integrated into downtube
- Battery is removable and lockable
- Chargeable internally and externally

### HEADSET

- All bearings fully integrated
- Upper: 1.125" Campy-style 45° cartridge bearing
- Lower: 1.5" with 36° inner and 45° outer cartridge bearing (not compatible with other 1.5" lower bearings)
- All bearings and other headset parts are available on the Service Website

### WHEEL SPACING / REAR AXLE

- All frames feature 148 mm spacing
- Rear axles are 12mm thru axles with the `Syntace` standard (thread pitch 1.0)

### TIRE COMPATIBILITY

- All MY22 Tero models come stock with 29x2.35 tires
- Bikes with Drytech fenders: 2.35" is the max. tire width for sufficient clearance between tire and fender
- Bikes without fenders: 29x2.6" is the max. tire width for sufficient clearance between tire and frame
  - If other tires fit, also depends on tread, actual dimensions, etc.
  - CEN standard demands 6 mm clearance between tires and frame or fender

### BRAKE MOUNT / ROTORS

- Post Mount
- 6- bolt hubs
- Stock rotor size
  - 5.0 and 4.0 models: 200 mm
  - 3.0 models: 180 mm
- Max. rotor size: 200 mm



# THE CHASSIS

## FORK MEASUREMENTS & COMPATIBILITY

- All feature 110 mm travel, lockable
- Tapered steerers (1 1/8 - 1 1/2)
- Suntour forks: 46 mm offset
- RockShox forks: 42 mm offset
- All models with RockShox forks: 110mm spacing and 15mm thru axles
- All models with Suntour forks: 100mm spacing and 15mm thru axles
- PM 180 brake mounts
- Through-hole in fork crown to mount fender and the front light





# KEY COMPONENT DATA

## OVERVIEW: EQ VS. VON-EQ MODELS

| COMPONENT | EQ MODEL | NON-EQ MODELS | NOTES   |
|-----------|----------|---------------|---|
| LIGHTS    | YES      | NO            | All non-EQ models can be upgraded to EQ bikes by using the `TERO EQ KIT` (98922-5060), containing: <ul style="list-style-type: none"><li>• Drytech Fenders</li><li>• MIK HD rack w/ tail light</li><li>• Lezyne Hecto StVZO E65 front light</li><li>• Mounting hardware</li><li>• Installation guide</li></ul> The Tero kickstand (8922-3006) can be added separately. <ul style="list-style-type: none"><li>• Service part SKU: S219900005</li><li>• Aftermarket SKU: 98922-3006</li></ul> |
| RACK      | YES      | NO            |   |
| FENDERS   | YES      | NO            |   |
| KICKSTAND | YES      | NO            |   |





# KEY COMPONENT DATA

## TERO EQ: RACK, FENDERS, LIGHTS

### FENDERS

- Specialized DryTech with “Flextender Extensions” for best protection
  - Watch video to see how well they work - this is a real rider benefit, there are no other fenders that work that well
- 65 mm outer width
- Rear fender connected to rack
- Front fenders feature new oval alloy stays for a stiff and robust connection between fork and fender (no noise and minimal flex under side-loads)
- Rear light cable runs in plastic cable guides within the fenders

### FRONT RACK OPTION

All MY22 Turbo Active bikes accept the optional Specialized front rack

- Rack and plate will be available as aftermarket item spring/summer 2022
- SKU: 98922-5600 (TURBO FRONT RACK W/ PLATE BLK)
- Max. 10 kg load
- Rack comes with the (optional) plate
  - The plate is bolted to the rack
  - Plate creates a larger surface to carry adventure gear, such as tent, sleeping bag, etc.
- Rack is mounted to a 3-bolt adaptor plate, sitting on the 4-bolt interface behind the steerer tube face plate
- Mounting instructions provided through animation, including a note on light cable length
- Rack accepts the MIK adaptor plate and thus any MIK accessories
- Front lights always have to be moved from the fork crown to the rack adaptor plate

*Important: first production MY22 Vado/Como/Tero EQ bikes do not feature a long enough cable to mount the front light to the front rack; incompatible front lights have 120cm cable length (about 40 cm too short). Solution: extend the front light cable by 40 cm at motor area; ensure cabling is properly sealed with shrink tube. Standard light cables with a 0.40 mm<sup>2</sup> cross-sectional area can be used (Lezyne uses 22AWG cable thickness which equals 0.32 mm<sup>2</sup>)*

Examples how to use rack:

- Mount MIK adaptor plate to the Specialized basket to attach assembly to front rack
- Mount MIK adaptor plate to any suitable box/basket to attach assembly to front rack
- Mount Adventure Plate to front rack if rider wants a larger carrying surface

### REAR RACK - MIK HD SYSTEM

- Use these resources to learn about the system
  - [MIK Homepage](#)
  - [MIK Video](#)
- Makes the rack compatible with the [MIK ADAPTOR PLATE](#): This plate can be bolted onto a variety of accessories such as boxes or crates; the full assembly is then clicked into the rack interface
- To use MIK compatible accessories with standard racks, you can upgrade racks with the [MIK CARRIER PLATE](#): This adaptor clamps to any standard rack to use a MIK-ready accessory



### REAR RACK

- Specialized custom design w/ MIK HD interface to mount accessories such as child seat or basket
- Versatile and capable
- 27 kg max.
- ISO 11243 certified (see stamping) - some child seat options, e.g. Thule, require a rack that complies with that certification
- Fully integrated & protected rear light
- Rack is connected to rear fender
- Max. 27 kg load
- Compatible with pannier hooks
- Compatible with all standard panniers (pannier rail diameter: 10 mm)
  - Panniers are supported by two rack stays, so that they do not get into the spokes
  - Panniers cannot rub against frame (rack creates space between rear end and pannier backside)
  - Each horizontal rail features an adjustable pannier stopper to prevent pannier from sliding



# KEY COMPONENT DATA

## LIGHT DETAILS

The Tero EQ model is equipped with an LED headlight and tail light. The lights turn on automatically when the bicycle is powered on and can be turned off via the handlebar remote if desired (long press on F1 button).

### LIGHTS WHILE CHARGING

After initiating charging, the lights automatically power off to conserve energy and to extend light lifetime.



| 4.0 MODELS          |   |
|---------------------|---|
| FRONT LIGHTS        | <p>Lezyne Hecto E65</p> <ul style="list-style-type: none"> <li>• 210 Lumen</li> <li>• 65 Lux</li> <li>• fork-mounted</li> <li>• With reflector</li> <li>• StVZO compliant</li> </ul>  |
| REAR LIGHT          | <p>All models feature the identical, rack-integrated Spanninga Commuter Glow rear light:</p> <ul style="list-style-type: none"> <li>• fully rack-integrated in aluminum housing - cannot break when using the rack/rear light as handle to move bike</li> <li>• 50 miniature LEDs</li> <li>• 2,5 Cd (full angle)</li> <li>• replaceable (S225800006 - LGT REAR, SPANNIGA COMMUTER GLOW R581001, INTEGRATED RACK MOUNT, W/O WIRE)</li> <li>• Required light cable: S216800037 - ELE MY22 VADO/TERO REAR LIGHT CABLE, 12V, 2 WIRES</li> </ul> |
| AFTERMARKET OPTIONS | <ul style="list-style-type: none"> <li>• When choosing an alternative front light, ensure that it is rated and compliant with the country-specific regulations.</li> <li>• Front light motor port rating: 2 A x 12 V = 24 W</li> </ul>  |

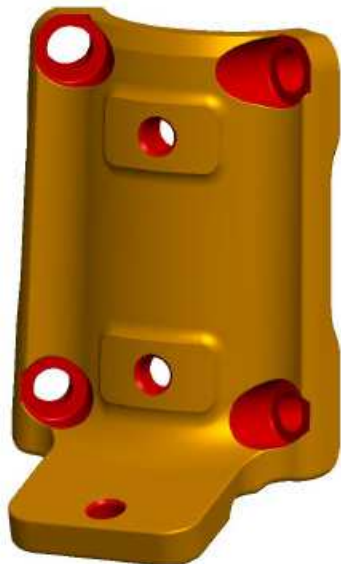

Machined Surface  
Front rack adaptor plated, bolted to the 4 steerer tube threads



Front rack, here combined with the Adventure Plate





# KEY COMPONENT DATA

## CONVERTING NON-EQ TO EQ MODEL

All non-EQ models can be upgraded to EQ bikes by using the `TERO EQ KIT` (98922-5060), containing:

- Drytech Fenders
- MIK HD rack w/ tail light
- Lezyne Hecto StVZO E65 front light
- Mounting hardware
- Installation guide

The Tero kickstand (8922-3006) can be added separately.

- Service part SKU: S219900005
- Aftermarket SKU: 98922-3006

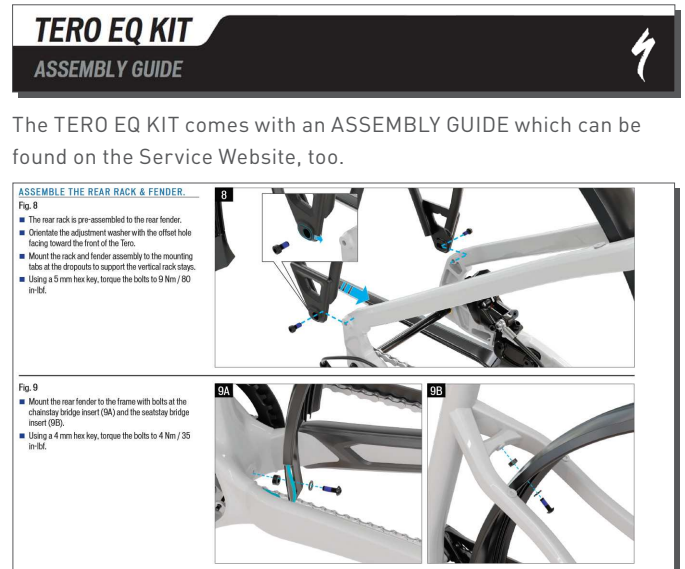

Excerpt of the TERO EQ KIT ASSEMBLY GUIDE

# KEY COMPONENT DATA

## COCKPIT

|            |  | TERO DETAILS   |
|------------|--|--|
| GENERAL    |  | All models use a traditional bar/stem combination with 31.8 mm clamp diameter.   |
| STEM       |  | All models come with a Specialized Stout stem: <ul style="list-style-type: none"> <li>• 3D-forged 6061-T6 alloy</li> <li>• 31.8 mm clamp</li> <li>• 6° rise</li> <li>• Lengths               <ul style="list-style-type: none"> <li>• 60 mm (S/M)</li> <li>• 75 mm (L/XL)</li> </ul> </li> </ul>   |
| HANDLEBARS |  | All models come with a Specialized Trail handlebar: <ul style="list-style-type: none"> <li>• 6061-T6 alloy</li> <li>• 31.8 mm clamp diameter</li> <li>• 680 mm wide</li> <li>• 6° upsweep / 27 mm rise</li> <li>• 8° backsweep</li> <li>• Widths               <ul style="list-style-type: none"> <li>• 720 mm (S)</li> <li>• 750 mm (M/L/XL)</li> </ul> </li> </ul> |





## KEY COMPONENT DATA

### SEATING AREA

|                |  | TERO DETAILS |
|----------------|--|--------------|
| SEATPOSTS      | <p>All seatposts:</p> <ul style="list-style-type: none"> <li>• Diameter: 30.9 mm</li> <li>• 0 mm offset</li> </ul> <p>Suspension seatposts:</p> <ul style="list-style-type: none"> <li>• Size S: 360 mm long / 100 mm travel</li> <li>• Size M/L/XL: 400 mm long / 120 mm travel</li> </ul> <p>Standard seatpost:</p> <ul style="list-style-type: none"> <li>• All frame sizes: 400 mm long</li> </ul> |              |
| SADDLE WIDTHS  | 155 mm (all frame sizes)   |              |
| SEATPOST CLAMP | <ul style="list-style-type: none"> <li>• 6061-T6 alloy</li> <li>• 34.9 mm (inner diameter)</li> <li>• Bolt clamp type</li> </ul>   |              |

## KEY COMPONENT DATA

### DRIVE-TRAIN SPECIFICATIONS

| DRIVE-TRAIN SYSTEM | SPECIFICATION   | OPTIONS  |
|--------------------|---|--|
| CHAINRING          | <p>Non-EQ models:</p> <ul style="list-style-type: none"> <li>• 36t</li> <li>• 104 BCD</li> </ul> <p>EQ models:</p> <ul style="list-style-type: none"> <li>• 40t</li> <li>• 104 BCD</li> </ul> | <p>With chain guide:</p> <ul style="list-style-type: none"> <li>• Min: 32t</li> <li>• Max: 40t</li> </ul> <p>Without chain guide:</p> <ul style="list-style-type: none"> <li>• Min: 30t</li> <li>• Max: 48t</li> </ul> |
| CRANK LENGTHS      | 170 mm (all models and frame sizes)   | Different, matching cranks can be mounted (e.g. from Levo or other aftermarket cranks with ISIS interface)   |
| CASSETTE           | <ul style="list-style-type: none"> <li>• 11spd: 11-42t</li> <li>• 9spd: 11-36t</li> </ul>   | Modifications require usual considerations such as derailleur capacity, chain length, etc.   |



# KEY COMPONENT DATA

## WHEELS & TIRES

### SPEC FOR ALL MODELS

- 29" wheels front and rear
- 32h alloy rims, double-wall alloy, 18.3 mm rim depth, 25 mm internal width
- DT Industry spokes and brass nipples; thread locker applied at factory
- DT tubeless ready rim tape, 27mm, with tubeless ready logo
- 29x2.35" Ground Control 2BR tires front and rear, T5 compound
  - tubeless ready (2BR)
    - tubeless-ready rim tape installed
    - tubeless valves are NOT included in small parts box
- Pressure recommendations
  - Tire sidewall: 22-50 psi (1.5-3.5 bars)
  - Based on ride experience for 80 kg rider, offroad use
    - front: 1.5-1.8 bars / 22-26 psi
    - rear: 1.7-2.0 bars / 25-29 psi

### TIRE OPTIONS

- Many alternative tires can be run
- Maximum tire widths
  - Bikes with Drytech fenders: 2.35" is the max. tire width for sufficient clearance between tire and fender
  - Bikes without fenders: 2.9x2.6" is the max. tire width for sufficient clearance between tire and frame
    - If other tires fit, also depends on tread, actual dimensions, etc.
    - CEN standard demands 6 mm clearance between tires and frame or fender



### FRONT WHEEL SPACING

- 110x15 on models with RockShox forks (= BOOST)
- 100x15 on models with Suntour forks (= STANDARD)

### REAR WHEEL SPACING

- 148x12
- Thru axles feature the `Syntace` standard (thread pitch 1.0)

### 650B WHEEL OPTION

- Running 650B" wheels is technically possible, but not recommended since Tero geometry is designed around 29" wheels.



# KEY COMPONENT DATA

## KICKSTAND

### NON-EQ MODELS

- No kickstand mounted, but retrofittable
- Kickstand mount holes in chainstay are covered with plastic plugs
- A bolted on sheet cover behind the chainstay prevents the speed sensor cable from interfering with the rotor

### EQ MODELS

- Kickstand mounted
- A sheet cover between chainstay and kickstand plate prevents the speed sensor cable from interfering with the rotor

### KICKSTAND SPECIFICATIONS

- Part number: 8922-3006
  - Service part SKU: S219900005
  - Aftermarket SKU: 98922-3006
- 40 mm mount (center-center of mounting holes)
- Length: 362 mm
- Provided they fit (mounting, length), alternative kickstands can be installed





# ACCESSORY COMPATIBILITY

## CARRYING SOLUTIONS & LOCKS

This table lists the most important bike accessories and provides the needed technical information as well as product links

### REAR RACK (EQ MODELS)



#### PANNIERS

- Accepts all standard panniers on pannier rails
- Rail diameter: 10 mm

#### MIK HD ACCESSORIES

- Compatible with MIK HD accessories

#### CUSTOM BAGS AND BASKETS

- Use the [MIK ADAPTOR PLATE](#)
- This plate can be bolted onto a variety of accessories such as boxes or crates; the full assembly is then clicked into the rack interface

#### CHILD SEATS

- Rack allows 27 kg max. (seats are usually limited to 22 kg)
- Compatible with MIK HD ready child seats, e.g.
  - [OGK urban iki MIK HD](#)
    - Clicks directly onto rack (MIK HD)
    - 9-22 kg
    - TÜV tested and approved
  - [Bubbly Maxi Plus](#)
    - Similar to OGK
  - [GO MIK HD](#)
    - Suitable for children up to 22 kg
    - Meets EN14344 safety standards
    - TÜV approved (European standard)

### FRAME

#### SPECIALIZED FRONT RACK

- Optional
- Rack is mounted to the 4-bolt interface behind the steerer tube face plate
- Rack accepts the MIK adaptor plate and thus any MIK accessories
- See details above

#### DROPPER POST

- Suitable 30.9 mm dropper posts with internal routing can be retrofitted
- About routing a dropper post cable
  - Drive-side frame entry ports in downtube accept additional housing
  - In motor area, cable routes past the motor tabs on the drive side
  - Cranks, spider/chainring and motor covers need to be removed
  - Motor can remain installed (removing it makes routing certainly easier)

#### TRAILERS

- All Tero frames are compatible with trailer use
- The tow limit is 132lbs / 60kg - refer to manual section `Riding with Kids` for details
- Hardware to mount a trailer hitch
  - Hardware to mount a trailer hitch: choose trailer-compatible 148x12 thru axle with 1.0 pitch, e.g. from [The Robert Axle Project](#)
  - Choose trailer-compatible 148x12 thru axle with 1.0 pitch, e.g. from [The Robert Axle Project](#)



# ACCESSORY COMPATIBILITY

## CARRYING SOLUTIONS & LOCKS

### LOCKS



#### FOLDING LOCKS

Top-tube mounting: The top tube rivet nuts in double diamond frames are positioned closer to the seat tube as known from e.g. Vado Gen1, for these reasons:

- All frame sizes accept a small folding lock + 26 oz bottle in downtube holder
- Mounting accessories such as pumps or alternative holders without interfering with a large water bottle at down tube

Customization tip:

- Use of [Wolf Tooth B-RAD Mounting Bases](#) to position accessories individually (would allow mounting a large folding lock or any other larger accessory)

Compatible folding lock at top tube rivet nuts:

- [Abus Bordo Lite Mini 6055](#) fits with this separate [SH 6055 holder](#) (allows locking frame to smaller pole, but needs to be positioned closely)

Down-tube mounting:

- Compatible with all Tero frames
- Tero Step frames either accept a folding lock or a water bottle cage

#### FRAME LOCKS (MOUNTED TO SEAT STAYS)

Requirements:

- Lock must be wide enough to clear fender/tire; fender width: 65 mm
- Lock mount tabs need to be compatible with frame tab spacing
- Seat stay tab distance for frame locks (center-center): 90 mm
- Recommendation: [Abus Shield 5750 Plus](#)
- Tip for many Abus locks: combine them with the matching adaptor chain that connects to the frame lock; allows securing the bike to a pole, fence etc.



# ACCESSORY COMPATIBILITY TRAILER USE

## GENERAL GUIDANCE

All Tero bikes are compatible with trailers. As Retailer, make Riders aware of and familiar with the manual section `Riding with Kids`. This section contains several important safety notes and warnings, centering around this:

[...] While Specialized bicycles are generally designed and tested for use by one person at a time, we were able to verify compatibility of certain child-carrying devices with specific bikes when installed in accordance with the manufacturer's instructions.

[...] You should make sure your bicycle is still safe to ride with the accessory installed and follow all of the safety instructions given by the accessory manufacturer

[...] Be sure to not exceed the structural weight limit and cargo weight limit of the bicycle if you use any bicycle-mounted child-carrying accessory except for an axle-mounted trailer, in which case the tow limit is 132 lbs / 60 kg. [...]

## TECHNICAL GUIDANCE

- All Turbo Tero models are compatible with trailers
- Trailer-mounting requires replacing the standard thru-axle with a trailer-compatible 148x12mm thru-axle (Syntace standard, pitch 1.0), e.g. from The Robert Axle Project.
- Dimensions of default 148x12 thru axle
  - Length: 172mm
  - M12 thread with 1.0 pitch

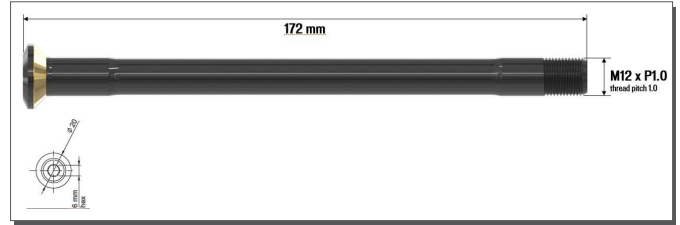

Default MY22 Turbo Vado/Como/Tero 148x12 rear thru axle (derailleur models)



Example of "Robert" 148x12 rear thru axle for trailer hitches (Syntace standard with conical washers)



Example of "Thule" axle part no. 20110733: 148x12 thru axle for trailer hitches (Syntace standard with conical washers - not shown in image)

# ACCESSORY COMPATIBILITY CHILDSEAT USE

The following applies to Turbo Tero EQ models or those upgrade with the original MIK HD rack for Turbo Tero.

- The rack features the MIK HD system to accept these compatible child seats:
  - [OGK urban iki MIK HD](#)
    - Clicks directly onto rack (MIK HD)
    - 9-22 kg
    - TÜV tested and approved
  - [Bubbly Maxi Plus](#)
    - Similar to OGK





# TURBO FULL POWER TECHNOLOGY

## GENERAL

All Turbo Tero models feature Full Power Systems with three different motor performance levels and two levels of battery capacity. The following overview focuses on key system components. Please refer to the Turbo Fully Power System Workbook to access all system details.

# TURBO FULL POWER TECHNOLOGY

## BASIC THEORY OF OPERATION

THESE COMPONENTS ARE PART OF THE CAN BIKE SYSTEM COMMUNICATION (COMPONENTS 'TALK' TO EACH OTHER):

1. MasterMind TCD (can be seen as the master of the bike, also allowing external communication)
2. Motor
3. Battery

The speed sensor and the remote act as switches and are not part of the bike communication as such.

WHAT HAPPENS WHEN PRESSING THE ON-BUTTON?

- Internal battery in the MasterMind TCD sends a wake signal to wake up the battery
- Battery sends 36V to the motor
- Motor sends 12V to the display and lights (if applicable)
- MasterMind TCD powers on
- Lights power on
- System is active

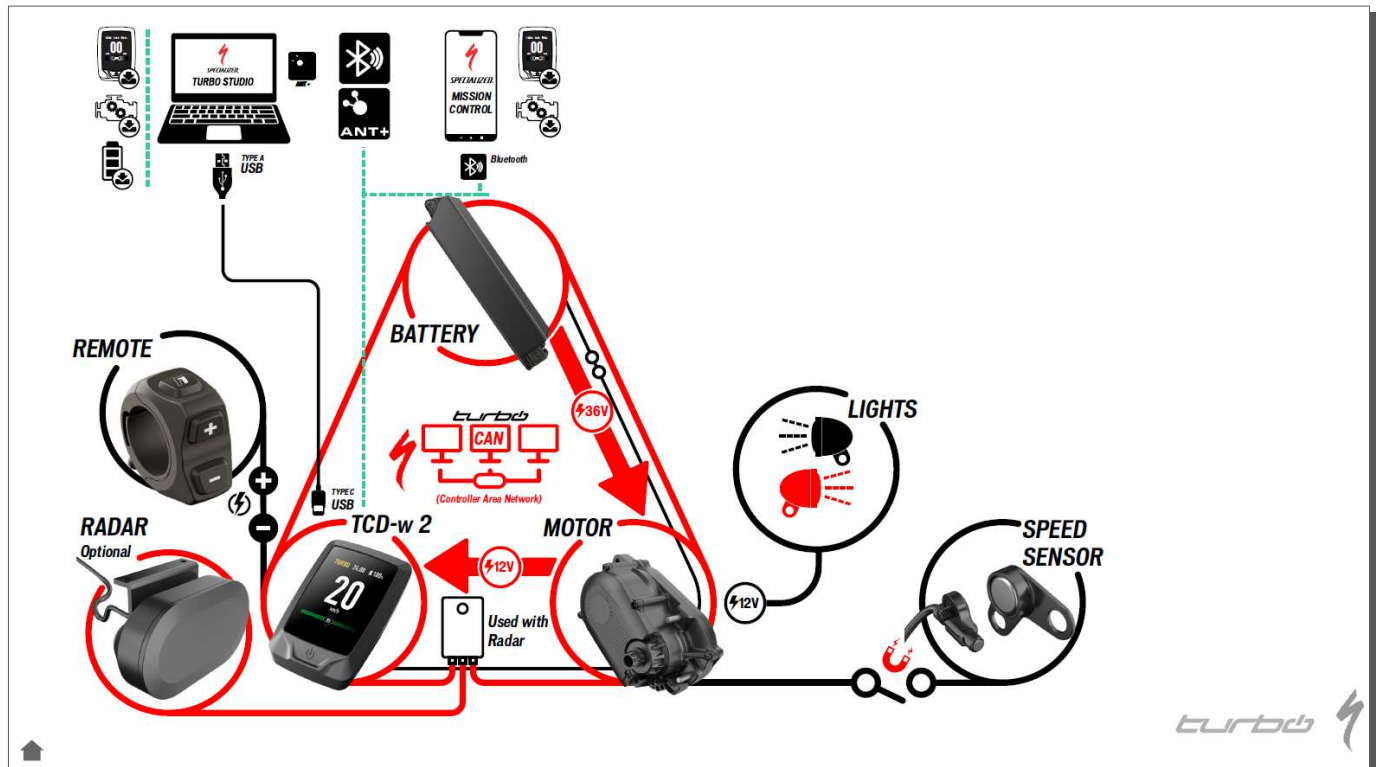





# TURBO FULL POWER TECHNOLOGY MOTOR

|  | ALL 5.0 MODELS  | ALL 4.0 MODELS                          | ALL 3.0 MODELS                            |
|--|---|---|---|
| SPECIALIZED NAMING                               | Specialized 2.2   | Specialized 2.0                         | Specialized 2.0E                          |
| MOTOR LABEL                                      | <ul style="list-style-type: none"> <li>E01680-100<br/>(Drive Smag, vertical)</li> <li>[E06855-100]<br/>(Drive Smag, horizontal)</li> </ul>  | E57026-100<br>(Drive T Mag, horizontal) | [E57028-100]<br>(Drive C Mag, horizontal) |
| NOTES ON HARDWARE & FEATURES                     | <ul style="list-style-type: none"> <li>Magnesium housing, coated</li> <li>Alloy cover side at the electronic board for better heat dissipation</li> <li>ISIS spindle</li> <li>Direct to frame mounting</li> <li>TBD: Compatible with Acceleration Response and Shuttle Mode in Mission Control App</li> </ul>                                   |   |   |
| NOMINAL OPERATING VOLTAGE / WORKING PRINCIPLE    | <ul style="list-style-type: none"> <li>36V</li> <li>Brushless motor with belt transmission</li> </ul>   |   |   |
| MAX TORQUE                                       | 90 Nm   | 70 Nm                                   | 50 Nm                                     |
| MAX. AND NOMINAL WATTS <sup>1</sup> (MECHANICAL) | 560 w<br>(250 nominal)  | 470 w<br>(250 nominal)                  | 430 w<br>(250 nominal)                    |
| RIDER AMPLIFICATION / X TIMES YOU <sup>2</sup>   | up to 410%<br>4x you  |   |   |
| APPROX. WEIGHT                                   | 2.95 kg   |   |   |
| LIGHT PORT OUTPUT                                | <b>Front light:</b> 2 A x 12 V = 24 W<br><b>Rear light:</b> 0.2 A x 12 V = 2.4 W  |   |   |
| PROTECTION RATING                                | IP 56   |   |   |
| WARRANTY TERMS (FROM DATE OF PURCHASE)           | 2 years   |   |   |
| SERVICING NOTES                                  | <ul style="list-style-type: none"> <li>Use the resources on the Service Website and in Turbo Studio Service Manager in case of service or replacement (e.g. service instructions or motor replacement video)</li> <li>Blind plugs: service motors ship without blind plugs: ensure they are transferred over from the previous motor</li> </ul> |   |   |

<sup>1</sup> • Mechanical vs. electrical output: max. mechanical output is defined in a third-party lab test; Mission Control displays the electrical consumption (watts) of the bike (stats field 'MOTOR POWER' in 'RIDE'). The max. electrical consumption is higher than the max. mechanical output, since efficiency can never reach 100%.

• Nominal power: Refers to the power output the motor can maintain over a defined period of time in a standardized test.

<sup>2</sup> • Refers to max. Rider power amplification to give Riders better understanding of how much support the motor adds. Definition: the system adds about 4 times the average Rider output which is a baseline value of around 135 watts; the x times you numbers are rounded



# TURBO FULL POWER TECHNOLOGY MOTOR

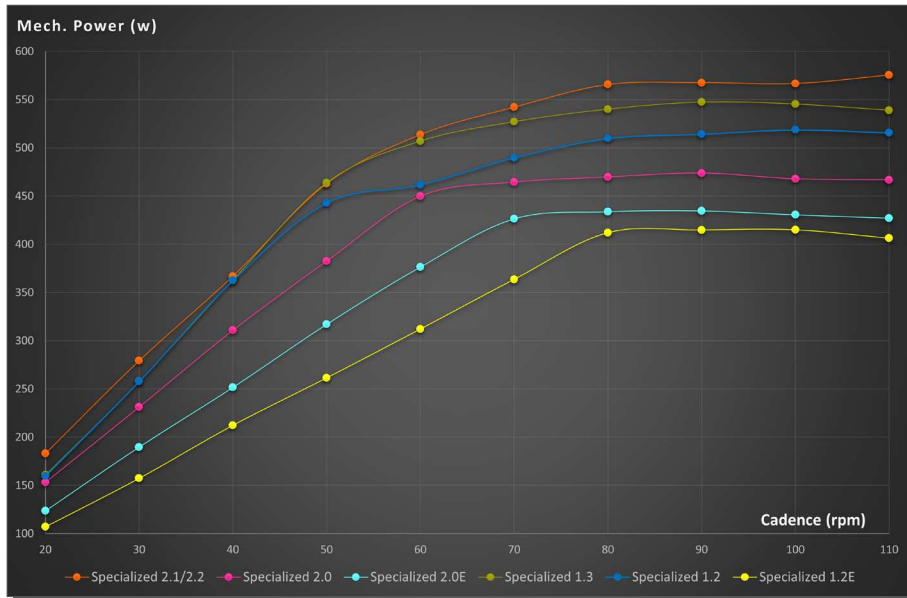

## PERFORMANCE CURVES - MECHANICAL POWER

- Simplified, the watt values refer to the motor support Riders get to keep their momentum - the higher the value, the easier it is to maintain a certain speed
- The watts stated in the graphs refer to the mechanical output, whereas Mission Control or some on-bike displays reference the electrical output - which is higher than mechanical output since efficiency can never reach 100%
- Benefit of all motors: they offer optimal support over a broad cadence bandwidth and keep it up even at cadences beyond 100 rpm - this adds a lot to the natural ride feel we all appreciate

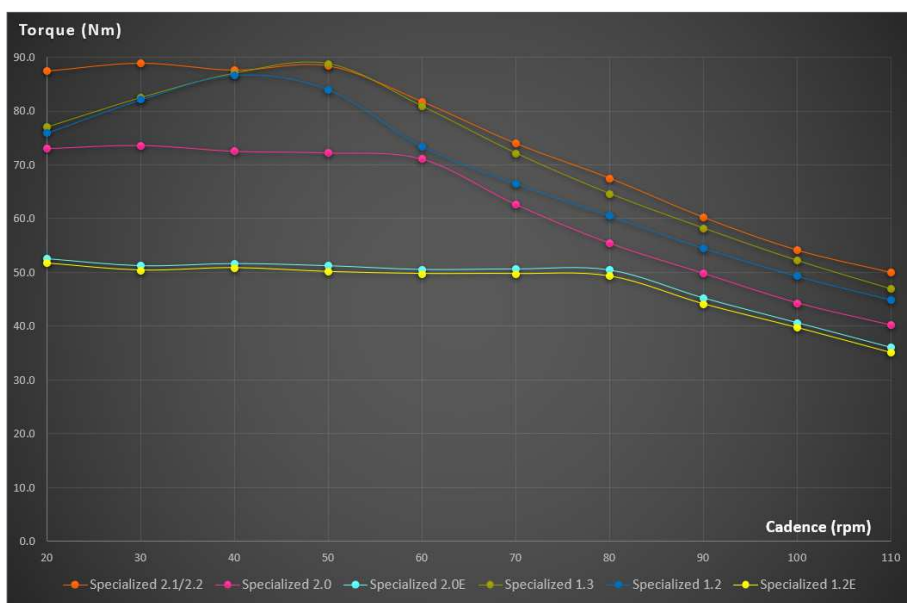

## PERFORMANCE CURVES - TORQUE

- Simplified, the newton meter values refer to the acceleration power and climbing performance a Rider would get - the higher the value, the easier it is to gain speed and to overcome steep inclines with ease
- Benefit of all motors: they offer a constantly high torque till cadences of 50 to 60 rpm for steady, natural acceleration and smooth climbing; going into higher cadence spectrums, the curves gently decrease, rather than dropping sharply; this mimics exactly the feel a Rider without motor assist would get and therefore contributes a lot to the natural Ride feel of our Turbo bikes



# TURBO FULL POWER TECHNOLOGY BATTERY

|   | ALL 5.0 AND 4.0 MODELS   | ALL 3.0 MODELS   |
|---|--|--|
| SPECIALIZED NAMING                                  | <ul style="list-style-type: none"><li>• Specialized U2-710</li><li>• SBC - B20</li></ul>   | <ul style="list-style-type: none"><li>• Specialized U2-530</li><li>• SBC - B19</li></ul> |
| CAPACITY  | 710 wh   | 530 wh   |
| WEIGHT W/O HARDWARE                                 | 3.9 kg   | 3.1 kg   |
| CHARGE TIMES<br>(FULL CHARGE W/ STD.<br>4A CHARGER) | 5:00 h   | 4:00 h   |
| NOMINAL VOLTAGE                                     | 36V  |  |
| WIRELESS CONNECTIVITY                               | <ul style="list-style-type: none"><li>• No</li><li>• Wireless connectivity included in MasterMind TCD</li></ul>  |  |
| PROTECTION RATING                                   | IPX 6  |  |
| REPLACEABLE HARDWARE                                | <ul style="list-style-type: none"><li>• Battery pin</li><li>• Lock guide</li></ul>   |  |
| WASHING ADVICE                                      | <ul style="list-style-type: none"><li>• No high pressure washing in general</li><li>• Leave battery installed</li><li>• Ensure charge port cover is closed</li></ul> |  |
| WARRANTY TERMS                                      | ≤ 75% of capacity after 300 charge cycles or 2 years   |  |



# TURBO FULL POWER TECHNOLOGY CHARGERS & CHARGING



SBC-C05 charger without power cord  
(market-specific cords ship with charger)



SBC-C07 charger without power cord  
(market-specific cords ship with charger)



## GENERAL

Always refer to the Turbo bike and/or charger manual for detailed information about charging. Here are some key points:

- Only use original and compatible chargers with Specialized e-bikes
- Do not use the charger with any other bicycle or any other charger with Specialized e-bikes, even if it fits
- Turn off the battery, unplug the charger from the battery and remove the battery from the bicycle before performing work of any kind, such as installation, maintenance, cleaning, repair and/or transportation
- When charging the battery:
  - Regularly inspect the charger for damage. Never use a charger that is damaged, or that you suspect to be damaged
  - Make sure the charging socket and plug are dry before connecting and charging the battery
  - Only use the Specialized charger supplied with the bicycle or other chargers approved by Specialized
  - Inspect the charger before every use for possible damage to the charger itself, the cable or the charging plug.  
Never use a charger which you suspect is damaged or know is broken.

|                                      | SPECIALIZED MODEL<br>SBC-C04   | SPECIALIZED MODEL<br>SBC-C07   |
|--------------------------------------|--|--|
| TERO MODEL                           | <ul style="list-style-type: none"> <li>• All models without "NB" in product name</li> <li>• Supplied with Gen 2 Turbo Active bikes that ship outside Europe</li> </ul> | <ul style="list-style-type: none"> <li>• All models with "NB" in product name ("No Battery")</li> <li>• NB bikes only go to European markets where this charger works with the standard household power outlets</li> </ul> |
| CHARGING VOLTAGE                     | 42 volts   |  |
| RATED VOLTAGE (AC)                   | 100 - 240 volts  | 230 - 240 volts  |
| CHARGING CURRENT                     | 4 amps   |  |
| CHARGING TEMPERATURE (BATTERY CELLS) | <ul style="list-style-type: none"> <li>• 0°C to +50°C</li> <li>• +32°F to +122°F</li> </ul>  |  |
| WEIGHT                               | approx. 900 g  | approx. 800 g  |
| NOTE                                 | This charger works globally  | This charger would not work with power outlets in countries where sockets are rated outside 230-240 volts (e.g. US = 110 volts).   |



# TURBO FULL POWER TECHNOLOGY

## BATTERY REMOVAL & INSTALLATION

### HOW-TO-RESOURCES

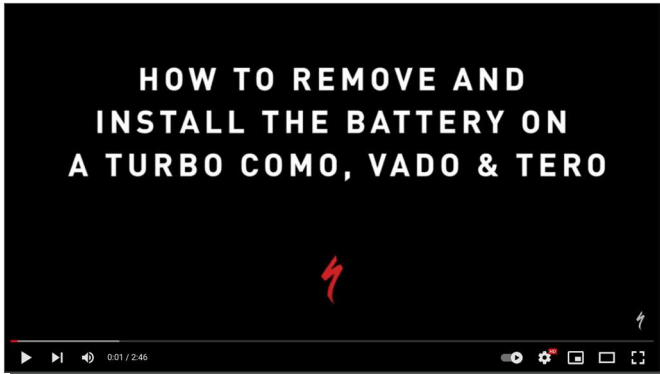

- Use resources as how-to reference
  - Bike manual
  - How-to-video on the [Specialized University YouTube channel](#)
- Be familiarize with process yourself
- Show Riders at handover

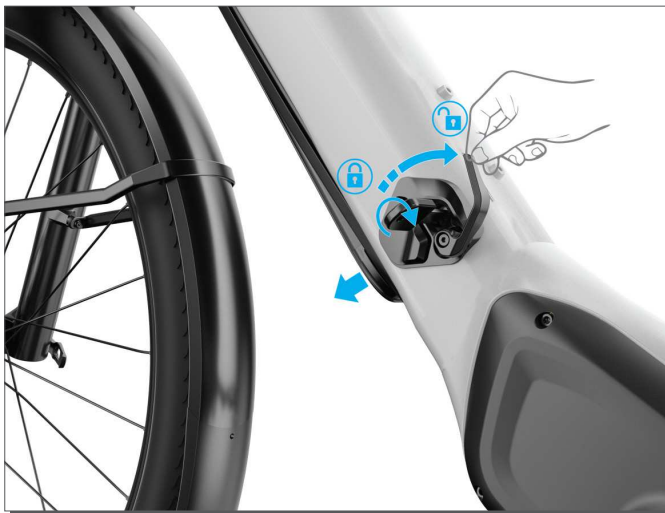

### GENERAL NOTES

- Turn off the bike first
- The battery is secured by the lock and can only be removed with the matching key
- The battery cannot fall out of the frame when released
- With a battery weight of almost 4 kg for the 710 wh pack, it is recommended to use both hands for full removal
- Angle the front wheel toward the non-drive-side to create the needed room for the battery

### REMOVAL INSTRUCTIONS

- Tilt the front wheel toward the non-drive-side
- Use the supplied key to unlock the battery
- Rotate the latch lever upwards to release the battery. The battery will stay supported on the hook even if it swivels out completely  
*Note: How far the battery moves out of the frame by itself depends on factors such as sealing lip condition, dirt accumulation and the like*  
*Tip: To help release the battery in case it does not move, keep the lever pressed up.*
- Rotate the battery down and align it at roughly 20 degrees with the downtube
- Lift the battery upwards and rearward to unhook it, then remove it with both hands
- Close the lever and remove the key if you prepared your bike for transportation

### INSERTION INSTRUCTIONS

- Tilt the front wheel toward the non-drive-side
- Hook the battery onto the hook and rotate it back into the frame
- Press the battery into the frame until the lock engages. You will feel and hear this
- Rotate the lever down to lock the battery latch
- Lock the battery lock with the key
- Remove the key
- Ensure the charge port cover is closed.  
*Warning: Do not ride the bicycle with the key inserted into the lock mechanism.*  
*Tip: Store one of the two supplied keys at home in a safe place. Note the key code in case you need to order spare keys. You can order them on <https://keyservice.axasecurity.com/>.*
- Power on the bike to check the connection

### BATTERY REMOVAL WITHOUT A KEY

- Information coming soon



# TURBO FULL POWER TECHNOLOGY

## BATTERY REMOVAL & INSTALLATION

### BATTERY REMOVAL WITHOUT A KEY

- Information coming soon





# TURBO FULL POWER TECHNOLOGY

## BATTERY LOCK MECHANISM

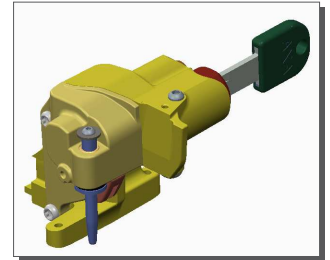
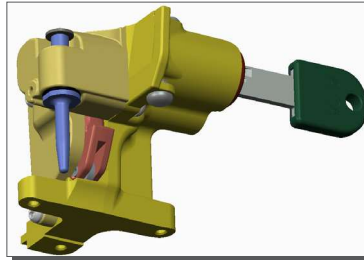
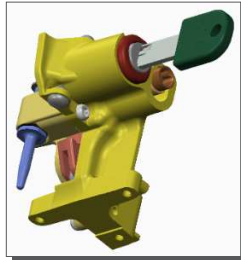
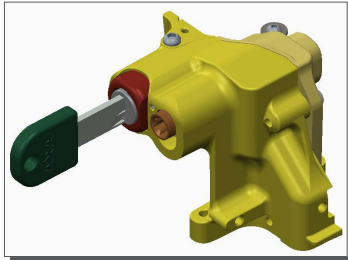

### GENERAL NOTES

- Lock systems are full assembled in the bike
- No adjustments required during bike building/before handover to Rider
- All bikes ship with two lock keys (AXA) with the key code engraved

### TECHNICAL INSTRUCTIONS

- Refer to the resources on the Service Website for technical drawings

### LOST KEY AND/OR LOCK MECHANISM REPLACEMENT

Scenarios which require key replacement or installation of a new locking mechanism:



#### 1. Both keys are lost, key codes are unknown or lock mechanism is damaged/not functional

- Replace cylinder + sleeve (service part)
- Lock cylinder can be drilled out to remove battery without key (Please contact Rider Care to learn about the recommended procedure)

#### 2. One key lost and/or key number known

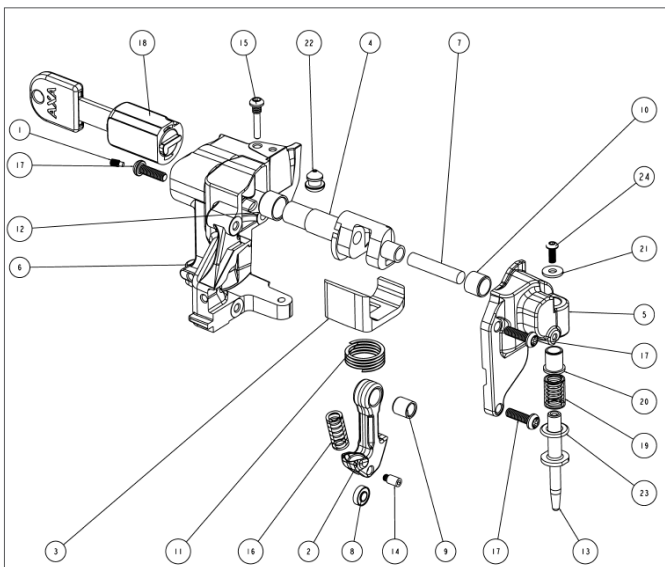
- Order new keys on AXA support site
- Retailers should create an account [here](#) to order keys on behalf of Riders (AXA ships keys to Retailers globally at reasonable prices)
- Riders from Europe (only) can order keys directly through this [AXA Key Service](#)
- Compatibility note: for Vado/Como/Tero lock systems, ONLY the long key works (labelled "Key Sol long" in below image)
- The short option will not work, it would interfere with the lock lever



|  |   |   |
|--|---|---|
|  |  <p><b>Key Sol xxxxx</b></p> <p>Suitable for locks:</p> <ul style="list-style-type: none"> <li>• AXA Rock</li> <li>• AXA Solid</li> <li>• AXA Battery lock</li> <li>• Basta RB1201</li> <li>• AXA Solid Plus</li> <li>• Basta RS1401</li> </ul> | <p><b>+ € 8,95</b></p> <p><small>Two keys maximum</small></p> |
|  |  <p><b>Key Sol long xxxxx</b></p> <p>Suitable for locks:</p> <ul style="list-style-type: none"> <li>• AXA battery lock</li> <li>• AXA Solid Plus</li> <li>• AXA Solid</li> </ul>  | <p><b>+ € 8,95</b></p> <p><small>Two keys maximum</small></p> |



# TURBO FULL POWER TECHNOLOGY

## MASTERMIND TCD

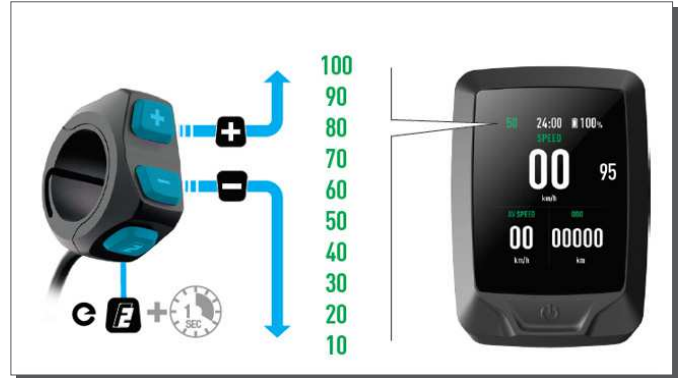
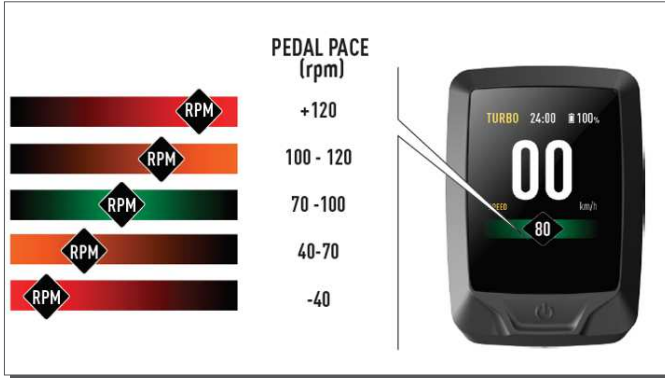

### WIRING AND ROLE IN SYSTEM

- Wired to motor and to handlebar remote
- Master of the bike (see Theory of Operation)

### KEY FEATURES

- Full color TFT display with IP66 / IP67 protection rating
- Diagonal screen size: 2.6" / 6.5 cm out of which 2.2" / 5.6 cm are used to display data
- Gorilla glass for robustness
- ON/OFF button for bike
- Customizable pages (Mission Control)
- Bluetooth / ANT+ connectivity
- USB C side-port (Turbo Studio connection / charging ext. devices with 1A)
- Efficiency coaching (color cadence bar; green indicates good cadence)
- Bike System Lock through Mission Control to disable motor support and additional MC connection
  - See details in section MISSION CONTROL
- Micro Tune in conjunction with remote
- Settings menu (manage various settings)
- Battery updates



### INTERNAL BATTERY

- Built-in battery, not replaceable
- Stores clock setting and allows error logging till 5 seconds after display turned off
- Needs to be sufficiently charged for the bike to power on
- If the bike does not power-on, ensure all cables are connected correctly, then connect the display to a power source via USB C cable to charge
- A fully charged internal battery will allow the bike to be powered on during 1 year without charging it or powering the bike on
- Designed to last as long as the expected bike life time





# TURBO FULL POWER TECHNOLOGY FIRMWARE UPDATES (WIRED)

The following applies to all Turbo Tero models.

## GENERAL

- Running wired firmware updates ensures the bike performs as intended at all times
- Wired updates can only be carried out by authorized Specialized Retailers with a Turbo Studio account

## WHEN TO CHECK FOR UPDATES

Firmware updates should be run through Turbo Studio in these scenarios:

- During the bike building process
- Before bike-handover to Rider
- Whenever a Rider brings a bike into the store

## HOW TO CONNECT & UPDATE

Please use the guide `How to connect & update` within Turbo Studio.



# TURBO FULL POWER TECHNOLOGY FIRMWARE UPDATES (WIRELESS)

The following applies to both Turbo Tero models.

- Riders can run firmware updates through Mission Control for displays and motors
- Battery firmware updates are generally not possible through wireless updates
- Whenever a later firmware is displayed under `Diagnose` in Mission Control, Riders are notified under `Device Updates`
  - In case of battery firmware, Mission Control asks Riders to visit their Retailer to get the update installed
- Matching instructions will be shared on the Specialized University YouTube channel. Example: [How to update your Turbo e-bike's TCU Display and Motor in Mission Control](#)





# WIRELESS CONNECTIVITY GENERAL

The following applies to all Turbo Tero models.

- All wireless connections are managed through the MasterMind TCD
- MasterMind TCD features built-in Bluetooth and an ANT+ modules

# WIRELESS CONNECTIVITY MISSION CONTROL APP

The following applies to all Turbo Tero models.

- Mission Control App is fully compatible with all bikes
- Please watch the Mission Control videos on the Specialized University YouTube channel

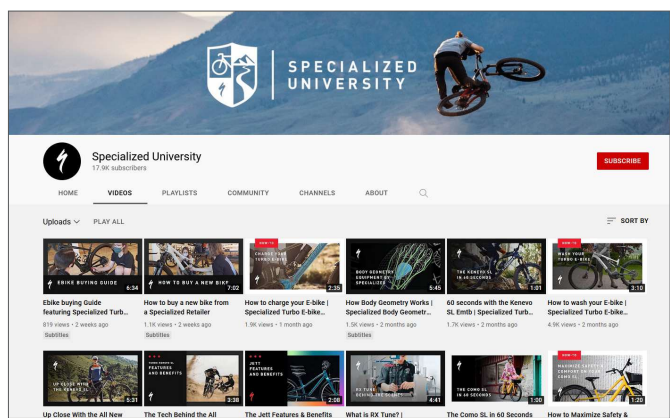

## VIDEO RESOURCES

Please visit the [Specialized University YouTube channel](#) to access the latest videos on Mission Control and other Specialized technology.

## INTRODUCTORY VIDEO:

[Managing your Turbo ebike with the Specialized Mission Control app](#)

## HOW-TO-VIDEOS

- [How to connect your Turbo ebike to Specialized Mission Control](#)
- [How to tune your Turbo ebike in Specialized Mission Control](#)
- [How to track your rides in Specialized Mission Control](#)
- [How to use Smart Control in Specialized Mission Control](#)
- [How to update your Turbo Connect Display \(TCD\) in Mission Control](#)

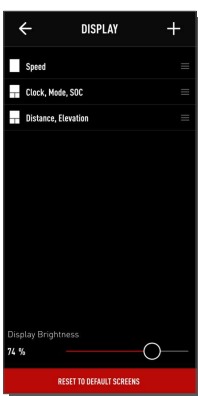
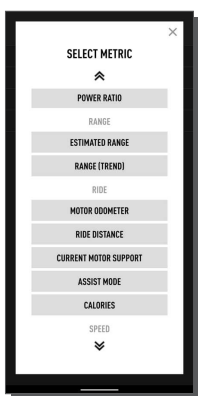
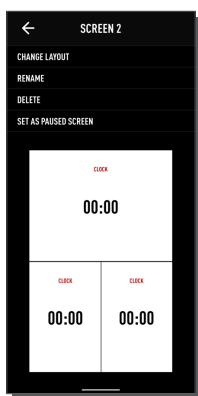
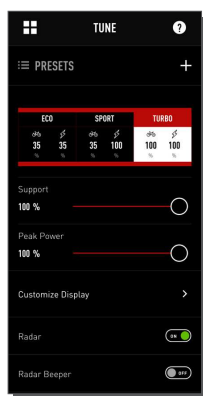

- TUNE menu to customize motor settings, display and more
- Manage new or existing screens
- Select from over 30 metrics to display on screens
- See display screens, add and manage screens, change display brightness
- Select from 6 display layouts

## FEATURE SUMMARY

- Customize the motor settings and create presets
- Customize Garmin Radar settings (wired systems)
- Engage Turbo System Lock
- Customize MasterMind TCD
  - Create new display fields, choosing from several screen layouts and over 30 metrics
  - Manage existing display screens (remove, custom-name, set paused screen)
  - Adjust display brightness

- Diagnose the bike
- Record, save, analyze rides and upload them to third-party platforms
- Run over-the-air updates for motor and display
- Register your bike



# WIRELESS CONNECTIVITY

## TURBO SYSTEM LOCK

The System Lock feature is compatible with all Turbo bikes featuring a MasterMind TCD and, at a later stage, MasterMind TCU displays.

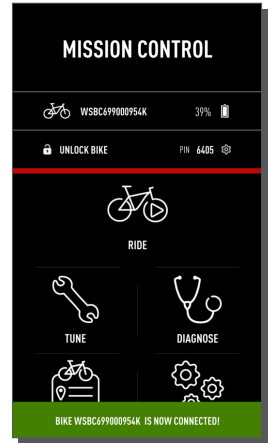
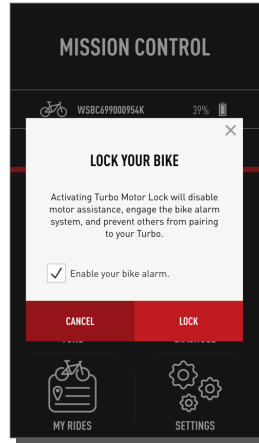
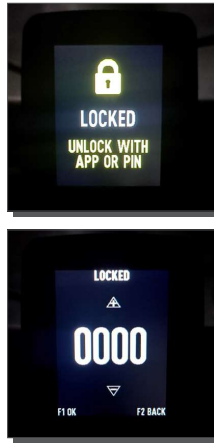
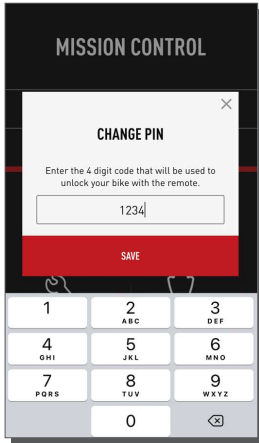

On first bike connection, a 4-digit lock pin will auto-generate. The Pin can be customized. Lock bike by tapping on lock symbol.

When powering on a locked bike, MasterMind TCD will show locked state, stating two unlock options. Pin entry field opens by pressing a remote button.

Have the ability to lock your bike with/without your bike alarm enabled.

After powering on, with the Mission Control app open, the app will connect to the bike. Unlock bike by tapping on lock symbol.

### WHAT IT DOES

- The all-new Turbo System Lock in Mission Control app disables the bike's motor and activates the motion sensor alarm
- Once locked, the motor cannot be enabled again except by the owner
- Owners can also set up a customized PIN code. The PIN code is entered through the handlebar remote as a backup in case the Rider is unable to use their phone to unlock their bike

### AUTHORIZED SPECIALIZED RETAILERS

- For bikes that have had their Turbo System Lock activated, the Retailer cannot work on the motor system until it has been unlocked, using the Mission Control app or the personal PIN
- Retailers cannot enable a motor without the PIN

### FEATURE SUMMARY

- Alert bike display messaging
- Optional anti-theft alarm sound
- Disable motor support: On Turbo System Lock activation, the bike will no longer provide motor support
- Custom lock pin - Riders can define the pin they want to unlock their bike
- App control - Lock and unlock with a single tap in Mission Control
- Handlebar remote unlock - Run out of phone battery, no worries. Riders can also unlock via the handlebar remote
- Alert light mode for bikes with connected lights

### CONDITIONS FOR ENABLING TURBO SYSTEM LOCK

1. Bike registration
  - The registration flag will be given through the registration flow in [Specialized.com](https://www.specialized.com), Mission Control or Ride App; this includes proof of purchase
  - Note: The Handover process within Service Manager also supports the feature: At the bottom of the service form, there is an email input field where the Retailer enters the owner's email address. Once the handover is saved or completed, the owner will receive the 'Bike Purchased' email, if the bike has not been previously registered. If the bike is already registered to the owner, he or she will be able to make use of the System Lock feature when connecting to Mission Control*
2. Mission Control app installed
3. Compatible bike (models with MasterMind TCD and, at a later stage, MasterMind TCU displays)



## WIRELESS CONNECTIVITY THIRD PARTY ANT+ OPTIONS

The following applies to all Turbo Tero models.

- The MasterMind TCD is capable of connecting third party ANT+ devices, for instance:
  - Heart rate belts (ANT+ or Bluetooth belts)
  - Garmin Varia ANT+ Radar systems (see Radar section)
- To pair/manage a device, you need to enter the MasterMind TCD setup menu



Pair BLE/ANT+ devices under "Sensors"

## WIRELESS CONNECTIVITY GARMIN WIRELESS RADAR

- The wired Garmin Radar system is not available aftermarket
  - Option for models without a wired remote:
    - A Garmin Varia ANT+ Radar can be paired to both MasterMind TCD and MasterMind TCU
    - Pairing happens in display setup menu (ANT+ and BLE sensors can be added/removed)
    - Dots show on display and alerts work
- Note: Turning off the radar gives an error message (because it is considered dangerous when the connection drops and you are not aware)*





# RANGE & RIDE TIME

## RANGE CONVERSATION & RANGE VARIABLES

### RANGE CONVERSATION

We recommend doing the following to give Riders realistic range orientation and to take away any potential `Range Anxiety`:

- Offer test ride(s) that allow Riders to mimic their intended use
- Use range examples and speak out of your own experience
- Give key ride tips to get best range results

### MAIN RANGE VARIABLES

Most riders are aware that range depends on many variables, but should you need to highlight some, just pick the top 5 or 6 variables of this list:

- Battery capacity
- Support and Peak Power settings
- Speed setting
- Terrain (elevation, surface)
- Drivetrain system & condition
  - A badly maintained chain drive system has a negative effect on range
- Rider/system weight
- Speed
- Rider input
- Ride style
- Rider cadence (sweet spot: rpm 75+)
- Ambient temperature
- Rider height
- Amount of starts/stops
- Sitting position
- Wind conditions
- Tire setup (type and pressure)
- Apparel (aerodynamics)
- On-bike accessories
- Additional variables

# RANGE & RIDE TIME

## TIPS TO OPTIMIZE RANGE

- Use Mission Control App to lower Support and Peak Power to reduce battery consumption and increase range
- Activate Smart Control - watch this video on How to use Smart Control in Specialized Mission Control
- Ride in smooth cadence for best motor efficiency (rule of thumb: 75 rpm and higher)
  - Stay in the green zone indicated on the MasterMind TCD cadence bar
- Ride with foresight, coast as early as possible and try to carry speed
- Avoid wearing floppy apparel
- Avoid carrying unnecessary weight/bulk (backpack, panniers, etc.)
- Maintain your bike regularly
- Keep tires inflated to appropriate pressure
- Regularly clean, lube and maintain a traditional chain/cassette drivetrain





# RANGE & RIDE TIME

## SIMPLIFIED RANGE TABLES

We tracked several rides to create simplified range tables for each speed limit and to cover IGH bikes and models with standard drivetrains. The range orientation in the tables is based on tracked rides along these parameters:

- \*Motor Support/Peak Power in %, default settings, customizable in Mission Control App
- Note on default Sport (35/100): the range difference versus default Eco gets bigger with climbing more and increased rider input, especially with 20 mph/28 mph motor assist speed limits
- Max. 80 kg rider incl. gear
- Flat to hilly terrain
- Full battery capacity used
- Average rider input around 100-135 watts
- Average cadence around 75 rpm
- Moderate ambient conditions (neutral wind, temperatures above freezing, etc.)
- Multiple variables influence range (motor/battery type, max. motor assist speed, tune settings, rider and terrain/environment variables, etc.)

| BATTERY / MOTOR                                 | ECO (35/35)*                             | SPORT (35/100)*                           | TURBO (100/100)*                        |
|---|--|---|---|
| <b>TURBO TERO, 25 KPH MOTOR ASSIST</b>          |  |   |   |
| 710 WH + MOST POWERFUL 2.2 MOTOR                | • Up to 120 km / 75 mi<br>• Up to 5:30 h | • Up to 100 km / 62 mi<br>• Up to 4:30 h  | • Up to 70 km / 44 mi<br>• Up to 3:00 h |
| 710 WH + POWERFUL 2.0 MOTOR                     | • Up to 145 km / 90 mi<br>• Up to 6:30 h | • Up to 120 km / 75 mi<br>• Up to 5:30 h  | • Up to 90 km / 56 mi<br>• Up to 3:30 h |
| 530 WH + MOST EFFICIENT 2.0E MOTOR              | • Up to 110 km / 68 mi<br>• Up to 5:00 h | • Up to 80 km / 50 mi<br>• Up to 3:30 h   | • Up to 50 km / 31 mi<br>• Up to 2:00 h |
| <b>TURBO TERO, 32 KPH / 20 MPH MOTOR ASSIST</b> |  |   |   |
| 710 WH + MOST POWERFUL 2.2 MOTOR                | • Up to 105 km / 65 mi<br>• Up to 5:00 h | • Up to 85 km / 53 mi<br>• Up to 4:00 hrs | • Up to 60 km / 37 mi<br>• Up to 2:15 h |
| 710 WH + POWERFUL 2.0 MOTOR                     | • Up to 125 km / 78 mi<br>• Up to 5:30 h | • Up to 105 km / 65 mi<br>• Up to 4:30 h  | • Up to 78 km / 48 mi<br>• Up to 3:00 h |
| 530 WH + MOST EFFICIENT 2.0E MOTOR              | • Up to 95 km / 60 mi<br>• Up to 4:30 h  | • Up to 70 km / 44 mi<br>• Up to 3:00 h   | • Up to 43 km / 27 mi<br>• Up to 1:45 h |

**MY22 TURBO TERO 5.0 - 20 MPH - DEFAULT ECO MODE**

**The Bike**

Model: MY22 Turbo Tero 5.0, Large  
 Weight: ca. 24.5 kg / 54 lb (as shown)  
 Speed Setting: 32 kph / 20 mph  
 Motor: Specialized 2.2  
 Battery: 710 Wh  
 Support Level: default Eco (35% / 35%)  
 Start Battery Charge Level: 100%  
 Finish Battery Charge Level: 5%  
 Tires: Specialized Ground Control 29x2.35"  
 Tire Pressure: 2.5 bar / 35 psi (front and rear)

**The Ride**



Open road ride around Salt Lake City  
 Distance: 92 km / 57 mi  
 Total Elevation Gain: 2287 m / 7503 ft  
 AVG speed: 18.3 kph / 11.4 mph  
 Ride time: 4h 59 min

**The Rider**

Height: 175 cm / 5 ft 9 in  
 Weight: 75 kg / 165 lb  
 AVG Power (weighted): 147 watts  
 AVG Cadence: 71 rpm

**The Weather**

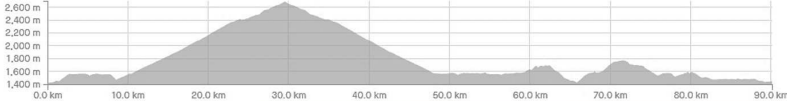
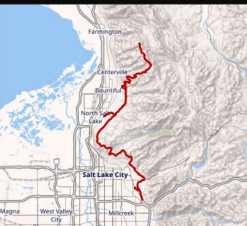
Dry and calm  
 AVG Temp: 26°C / 79° F

Distance: **56.69mi**

Duration: **04:59:20**

Average Speed: **11.36mph**



# BIKE BUILDING & SERVICE OVERVIEW

## ESSENTIAL RESOURCES

- All bike building and servicing resources are archived on the [Service Website](#)
- Visit any Turbo Tero model to access the needed information

## UNBOXING & BIKE BUILDING

- All bike building and servicing resources are archived on the [Service Website](#)
- Visit any Turbo Tero model to access the needed information

## MOTOR AND BATTERY REPLACEMENT

- All bike building and servicing resources are archived on the [Service Website](#)
- Visit any Turbo Tero model to access the needed information

## SMALL PARTS SCHEMATICS

The `Small Parts Schematics` provide rich technical guidance on cabling/wiring, cockpit setup, installation of Turbo components, bolts and torques, hardware specifications, and much more.

SCHEMATIC: 2022 VADO-COMO-TERO - SMALL PARTS SCHEMATICS

SCHEMATIC: 2022 VADO-COMO-TERO - CABLE SCHEMATICS

SCHEMATIC: 2022 VADO-COMO-TERO - SMALL PARTS SCHEMATICS

2022 VADO COMO TERO - MOTOR & BATTERY LATCH REMOVAL



<https://player.vimeo.com/video/604055880> Copy

2022 TERO - OUT THE BOX ASSEMBLY GUIDE



<https://player.vimeo.com/video/616015342> Copy

## TECHNICAL GUIDE

### SCHEMATIC - SMALL PARTS



### Phase 1. Handover preparation

Max. 60 minutes total handover time.

- Step 1 45 min **Prep Turbo in workshop for Rider handover**

1. Equip with all additional accessories
2. Update to latest firmware versions (Turbo Studio / third party electric components such as Di2 or AXS).
3. Match bike and small parts, manuals, charger, etc. (in soft case).
4. Charge batteries (Turbo and third party electric components).
5. Final technical check and test ride.

[add notes](#)

### Phase 2. Handover process

- Step 1 5 min **Do standard bike setup.**  
Skip if already set up in workshop.

1. Saddle height
2. Tire pressure
3. Suspension setup

[add notes](#)

- Step 2 5 min **Explain basic bike functionality.**  
Skip if done previously during test ride.

1. Turbo system: on/off, display basics, mode indication/switching, state of charge
2. Display: show some additional important functions and metrics
3. General: shifting, braking, dropper post actuation, etc.

## RIDER HANDOVER

Service Manager within Turbo Studio will soon guide Retailers through bike handover scenarios to ensure Riders are set up appropriately and have all important information right from the beginning.

Handover procedures are structured in 3 phases with concrete steps to carry out



# BIKE BUILDING & SERVICE

## DIAGNOSTICS & TROUBLESHOOTING

This section outlines the diagnostics and troubleshooting resources we provide.

### GENERAL

- Differentiate between normal system behavior and functional issues
- Make sure firmware is up-to-date before diagnostics process
- Go about logically and systematically
- Run digital diagnostics with all MasterMind TCD/TCU/ TCD-w bikes - use the Event Log and Service Actions in Turbo Studio
- Make use of remote diagnostics with Riders. Ask them to upload their 'Advanced Diagnostic' through Mission Control before looking up the bike serial number (WSBCxxxxxxxx) in Turbo Studio to give advice based on Event Log
- Have relevant Service Parts at hand

### DIAGNOSTICS GUIDE IN TURBO STUDIO

- Within Turbo Studio, you will find a Diagnostics Guide that allows you to run step-by-step diagnostics in case of functional issue with the Turbo e-bike system of any Turbo bike
- The additional Knowledge Base inside Turbo Studio allows you to access contextual information, such as definitions for error messages

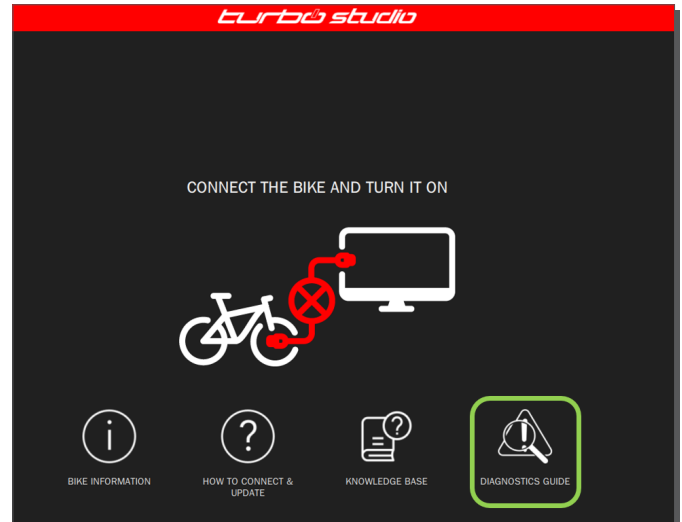

To access the Diagnostics Guide, click on the matching symbol on the Turbo Studio start screen.





## SERVICE & REPAIR (RETAILER) SERVICE PARTS

- Turbo Tero Service Parts are available at point of market introduction
- Please refer to the specific bike model on the Service Website to identify the needed Service Part

## SERVICE & REPAIR (RETAILER) SPOKE LENGTHS

Spoke lengths apply to default wheel setup and in combination with 12 mm nipples.

|          | SPOKE LENGTHS<br>FRONT |                | SPOKE LENGTHS<br>REAR |                |
|----------|------------------------|----------------|-----------------------|----------------|
|          | DRIVE SIDE             | NON-DRIVE-SIDE | DRIVE SIDE            | NON-DRIVE-SIDE |
| TERO 5.0 | 282 mm                 | 281 mm         | 280 mm                | 282 mm         |
| TERO 4.0 |                        |                |                       |                |
| TERO 3.0 | 285 mm                 | 284 mm         | 284 mm                | 285 mm         |



# GUIDELINES & TIPS

## RIDING TIPS

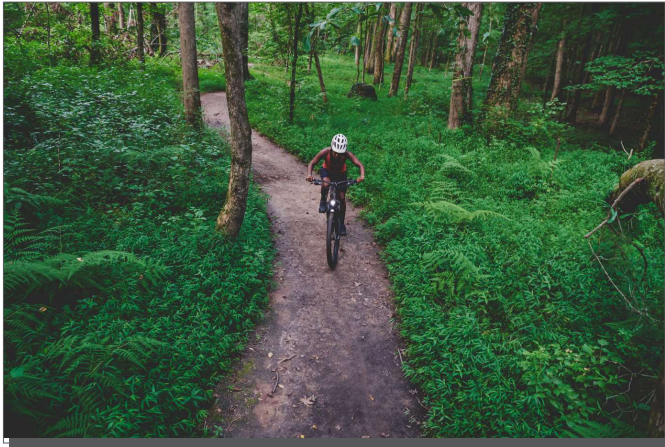

| RIDE TIP  | BENEFIT  |
|---|--|
| Pedal in a smooth cadence spectrum<br>(rule of thumb: 75 rpm and higher)              | Gives rider optimal motor support and ensures best range/efficiency    |
| Use the Pedal Pace Bar on MasterMind TCD:<br>staying in the green zone is recommended | The motor keeps up support at higher cadences,<br>also beyond 100 rpm  |
| Relieve pedaling force shortly before/during shifting                                 | Limits drivetrain wear and facilitates smooth shifting                 |
| Use Mission Control App to customize the ride   | 'Tune' menu allows customizing/controlling motor performance and range |
|   | 'Smart Control' allows managing range based on different parameters    |

# GUIDELINES & TIPS

## TRANSPORTATION TIPS

The video focuses on transportation on the road by car. Note that you cannot transport any Turbo e-bike with a bike battery installed on passenger airplanes. Refer to your airline for full details.

**SOMETIMES**  
**IT'S US, ONLY FASTER**  
**THIS REFERENCE WILL BE ADDED SOON**



# GUIDELINES & TIPS

## CLEANING GUIDELINE

### CHECK-STEPS BEFORE CLEANING

- Always turn the bicycle off before cleaning
- Leave the battery in the frame
- Ensure the charge port cover is closed

### AFTER WASHING/BEFORE BIKE USE

- Allow more sensitive areas to dry out, for instance leave the charge port door open and/or remove the battery to allow air-drying
- Make sure the charge port is free from water and/or dirt - if contaminated, remove the battery to remove contamination with low air pressure or a soft brush
- Clean and relube the drive train system, using a lint-free rag and high-quality chain oil. Ideally, you do this before/after each ride
- For instructions on how to maintain third party components, refer to the respective manufacturer's instructions

### WASHING/CLEANING RULES



Use the [7](#) on the Specialized University YouTube channel

- Never use a high-pressure cleaner or high-pressure hose when cleaning your Turbo bike
- Best practice is to use a bucket of water with a wet cloth or a sponge
- Never point water directly at sensitive areas such as the drivetrain, suspension parts, the dropper post, all bearings and seals, the motor area, batteries, displays and all electronic connectors
- Regularly clean the magnet on the rear wheel with a cloth. Brake dust with metal parts can collect and cause issues
- For instructions on how to clean third party components, refer to the respective manufacturer's instructions



# GUIDELINES & TIPS

## STRUCTURAL WEIGHT LIMITS

- The structural weight limit for Turbo Tero bikes is stated on the frame sticker, adhered to the underside of the downtube (see image).
- 136 kg is the structural weight limit for all models
- Definition of 'Structural weight limit': The maximum total weight (rider and cargo) a bike is designed and tested to support structurally
- You find detailed information on weight limitations in this document: 'SPECIALIZED BICYCLE OWNER'S MANUAL: APPENDIX A - RIDER/BIKE WEIGHT LIMITS AND TERRAIN CONDITIONS
- Find it on the Service Website and on specialized.com, archived under the manuals drop down for every bike model

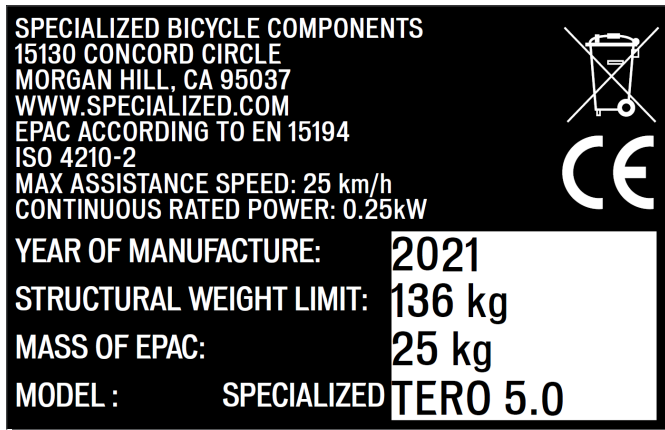

Example of the EN15194 sticker on a Turbo Tero (downtube of bike)

**INTRODUCTION**

This Appendix A manual supplement is designed as an annual addition to the Appendix A section found in the Specialized Bicycle Owner's Manual. This appendix is designed to help the rider determine if a bike is suitable for the intended use and the combined Rider Weight and Cargo Weight.

Each bike model has an intended use and is designed and tested to support a Structural Weight Limit, which includes a Cargo Weight Limit. As the weight of the rider approaches the Structural Weight Limit of the bike, the allowable Cargo Weight might be reduced. For example, a bike may have a 50lb Cargo Weight Limit, but if the weight of the rider is too close to the bike's Structural Weight Limit, the rider may only be allowed to carry a smaller amount of cargo or no cargo at all. See the following page for a model-specific example and graphs.

**UNDERSTANDING WEIGHT LIMITS**

**FRAME STRUCTURAL WEIGHT LIMITS**

Structural Weight Limits for each bike are determined by Specialized through extensive lab testing, and are listed in the Bike Model, Structural Weight Limit and Cargo Weight Limit Tables.

|  |                                |  |
|--|--------------------------------|--|
|  | <b>STRUCTURAL WEIGHT LIMIT</b> | The maximum Total Weight (rider and cargo) a bike is designed and tested to support structurally.  |
|  | <b>RIDER WEIGHT</b>            | The weight of the rider in riding gear (e.g., jacket, helmet cam, hydration pack, helmet, etc.).   |
|  | <b>CARGO WEIGHT</b>            | The weight of any additional accessories (e.g., panniers, front/rear racks, saddle bags, handlebar bags, baskets, etc.) not accounted for in Rider Weight. |
|  | <b>CARGO WEIGHT LIMIT</b>      | The maximum Cargo Weight a bike has been designed and tested to support structurally.  |
|  | <b>TOTAL WEIGHT</b>            | The sum of Rider Weight and Cargo Weight.  |

**WARNING!** Failure to follow these instructions and exceeding the specified Structural Weight and Cargo Limits may impair the structural integrity of the bicycle and may cause serious personal injury or death. For riders at the Rider Weight Limit, you may not be able to carry cargo if the Structural Weight Limit is exceeded.

# GUIDELINES & TIPS

## USER MANUAL & YELLOW STICKER

- Every bike ships with a printed manual in the market language. The manual holds useful information for sales staff, mechanics and Riders alike.
- The Yellow Sticker sticker is adhered to the frame. It should be removed during the bike building process to be placed onto the last page of the manual for future reference.

### MAIN MANUAL CHAPTERS

1. INTRODUCTION
2. TERO COMPONENTS
3. GEOMETRY
4. GENERAL INFORMATION ABOUT YOUR VADO
5. GENERAL NOTES ABOUT RIDING
6. GENERAL NOTES ABOUT MAINTENANCE
7. GENERAL NOTES ABOUT ASSEMBLY
8. SYSTEM INTERFACE
9. MISSION CONTROL
10. BATTERY AND CHARGER
11. SPECIFICATIONS
12. DRIVETRAIN
13. REGULATORY STATEMENTS
14. EC - DECLARATION OF CONFORMITY

